

Broadband building amplifier

DASH-120



The new **DASH 120** series amplifiers were designed, considering the requirements of modern cable operators looking for a best quality of transmitted signal at a reasonable cost of investment.

The availability of wide regulation level enables the use of the amplifier in house networks of various sizes.

It provides best quality of signal and flat characteristics. Highly reliable power supplier and premium overvoltage protection guaranties continuous operation. In addition, the possibility of local or remote power supply ensures wide range of its applications. It is prepared for different band split configurations and can be adapted to even more.

The amplifier uses typical JXP plug-ins, allowing to minimize the diversity of needed control devices.

The **DASH 120** broadband amplifiers are designed for indoor installation only.

- High output level: 120 dBμV
- **1.2 GHz frequency range**
- **Designed for DOCSIS 3.1/3.0**
- Easy configuration
- Active or passive return path
- Input/ Output triple overvoltage protection
- **6kV Surge protection**
- **Ingress filter (switchable)**
- Locally or remotely powered depending on version
- High heat dissipation and shock resistant metal housing
- **Compact dimensions**

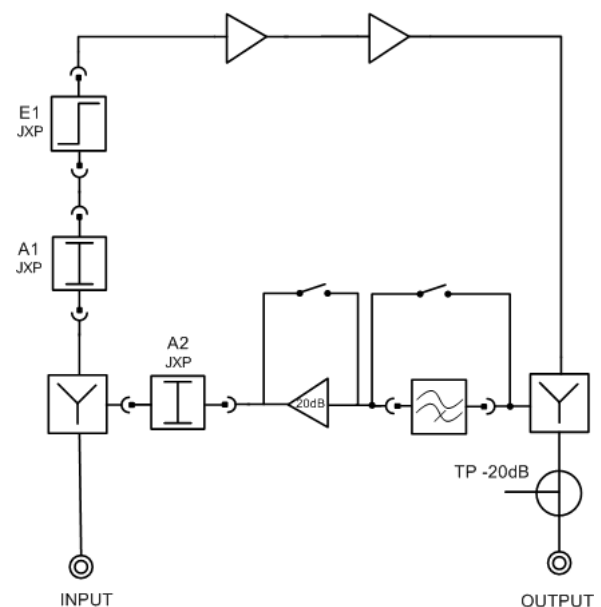

TECHNICAL PARAMETERS

PARAMETERS		DASH 120 xxS	DASH-120 xxZ
FORWARD PATH			
Frequency range	MHz	85,105...1218	
Gain	dB	34 ±1	
Flatness	dB	±0,75	
Max. output level (DIN 45004B)	dBμV	120	
Max. output level CENELEC 42, slope 9dB, CTB, CSO ≤ -60dBc	dBμV	107	
Input attenuator	dB	JXP plug-in: 0...20, step 1	
Input equalizer	dB	JXP plug-in: 0...20, step 1	
Test point	dB	-20 ±1	
Noise figure	dB	< 4,5	
Return loss at all inputs / outputs: - in the frequency range of 5-40MHz - in the frequency range of 40-1006MHz	dB	18 ≥18@ 40MHz – 1,5 / okt.	
RETURN PATH			
Frequency range	MHz	5...65,85	
Type of return path/ attenuation	dB	active/ JXP plug in:0...20, step 1	
Gain	dB	20 ±1 (active); -2 (passive)	
Flatness	dB	±1	
Max. output level (DIN 45004B)	dBμV	117	
Output attenuator	dB	JXP plug-in: 0...20, step 1	
Ingress filter	MHz	<17	
Noise figure	dB	<6,5	
OTHERS			
Operating voltage	V _{AC} / Hz	195...253 / 50-60 (local)	30...65 / 50-60 (remote)
Power consumption	W	<6,2	
Connectors	/	F	
Protection class	/	IP40	
Operating temperature	°C	-20...+60	
Surge protection	kV	6	
Weight	kg	0,7	
Dimensions	mm	155x80x53	
Package	/	box	
ORDERING INFORMATION			
Description	Name	Index	
DF 65/85 MHz, active return path, locally powered	DASH 120 AMS	I220-7538-386-01	
DF 85/105 MHz, active return path, locally powered	DASH 120 APS	I221-7538-386-02	
DF 65/85 MHz, active return path, remotely powered	DASH 120 AMZ	I222-7538-386-03	
DF 85/105 MHz, active return path, remotely powered	DASH 120 APZ	I223-7538-386-04	
DF 65/85 MHz, passive return path, locally powered	DASH 120 MS	I224-7538-386-05	
DF 85/105 MHz, passive return path, locally powered	DASH 120 PS	I225-7538-386-06	
DF 65/85 MHz, passive return path, remotely powered	DASH 120 MZ	I226-7538-386-07	
DF 85/105 MHz, passive return path, remotely powered	DASH 120 PZ	I227-7538-386-08	

Technical parameters may be changed without earlier notice.

www.telmor.pl