

## Distribution amplifier – 1.2 GHz

### TENAC 130



Series of "TENAC 130" amplifiers has been designed for professional multimedia cable TV networks which uses transmission in reverse path. Depending on output level there are two variants of amplifier. Usage of replaceable configuration modules allows wide choice of settings, according requirements.

Basic variant of amplifier is not equipped with any configuration modules – they have to be ordered separately.

Designed to work with DOCSIS 3.1 and 3.0 infrastructure.

- Hybrid Power Doubler output stage.
- Easy configuration - universal JXP plug-in modules with bypass for continuous transmission during config.
- Input / Output double overvoltage protection.
- Remote power supply transferable to any output.
- Robust, shock resistant metal housing.
- 2 RF Outputs – divided by splitter/tap
- Plug-in diplex filter for easy network upgrade

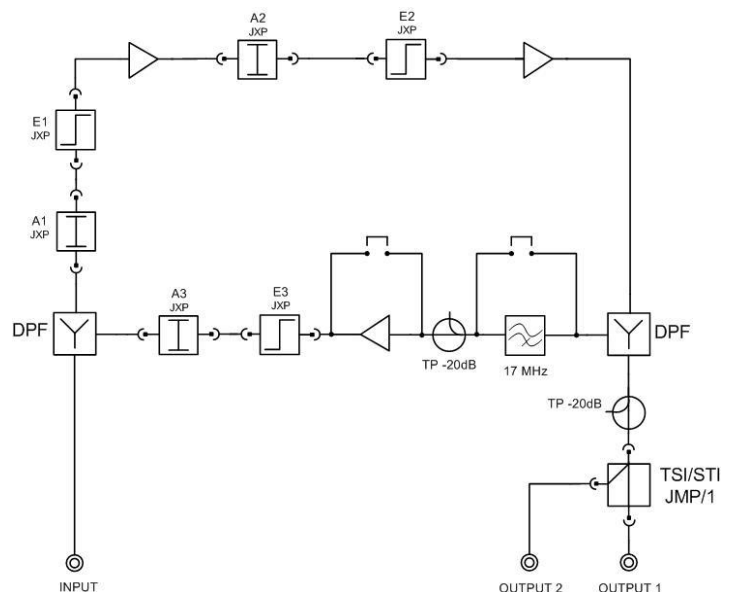

Technical parameters may be changed without earlier notice

[www.telmor.pl](http://www.telmor.pl)

# TECHNICAL SPECIFICATION

TENAC 130		
D O W N S T R E A M		
Forward Path Frequency Range	MHz	85,102,256 – 1218
Gain (typical)	dB	38
Gain Tolerance dB <sup>1</sup>	dB	+/-1
Flatness (102 to 1218 MHz) dB <sup>1</sup>	dB	± 0.75
Return Loss dB	dB	> 16
Group Delay	102 – 120 MHz	ns
	120 – 1218 MHz	ns
Noise Figure	dB	< 9
Max output level	dBμV	114
Interstage Attenuator	dB	Plug-in JXP 0-20
Interstage Equalizer	dB	Plug-in JXP 0-10
Attenuator	dB	Plug-in JXP 0-20
Equalizer	dB	Plug-in JXP 0-10
Hum Modulation	dBc	< -60
U P S T R E A M		
Return Path Frequency Range	MHz	5 – 65,85,204
Gain (typical)	dB	25
Gain Tolerance <sup>1</sup>	dB	+/-1
Flatness (5 to 40 MHz) dB <sup>1</sup>	dB	± 0.75
Return Loss	dB	> 16
Rated Output Level	dBmV	50
Group Delay	5 – 10 MHz	ns
	10 – 80 MHz	ns
	80 – 85 MHz	ns
Noise Figure	dB	< 9
Hum Modulation	dBc	< -60
G E N E R A L		
Input Voltage	VDC	30 ~ 90 (50-60 Hz)
Power Consumption	W	< 15
Attenuator dB	dB	Plug-in JXP 0-20
Equalizer dB	dB	Plug-in JXP 0-10
Surge Withstand	--	IEEE C62.41, 1.2/50us Combination Wave, ±6kV
Nominal Impedance	Ohm	75
Operational Temperature	°C / °F	-20 to +60 / +14 to +140
Water Proof	--	IP54
Regulatory Standards	--	RoHS compliant

1. Please see DF characteristics in bottom of datasheet.
2. CENELEC 42 (CTB, CSO < -60dB)

Technical parameters may be changed without earlier notice

[www.telmor.pl](http://www.telmor.pl)

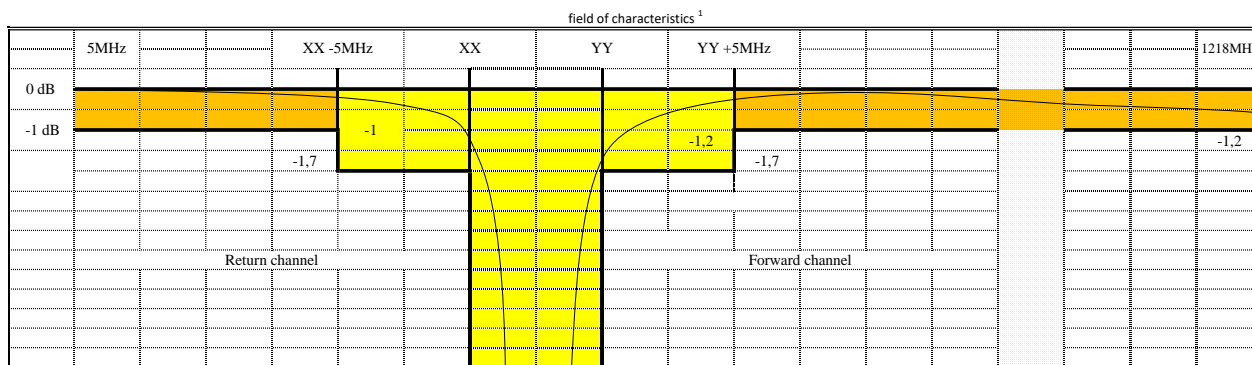

Amplifier amplitude characteristics should match a coloured background on the drawing

$R_{HLF}$  – return path higher limit frequency

$F_{LLF}$  – forward path lower limit frequency